

SPECIFICATIONS

Video standards supported according to the SMPTE 292M and 259M using YCbCr colour encoding. This level of integration and performance has been achieved utilising video processing and compression techniques optimised for reduced power consumption. The 10 bit all digital processing and the high stability crystals eliminate all noise and distortion. The long lasting battery life is a result of the latest power supply technology.

Video

Bit depth 10 bits
 Interface SMPTE 274M, 296M, 260M, 259M
 Bit rate 1.485 Gbit/s and 270 Mbits/s
 Output impedance 75 Ohm
 Video Connector BNC female
 Return Loss better than 15dB
 Amplitude 800mV +/- 10%
 Wideband Jitter < 0.2UI

AES Embedded Audio

Transport Audio embedded according to SMPTE 299M & 272
 Precision 20 bits
 Sampling Frequency 48kHz locked to video
 Tones 1kHz (nominal)
 444Hz (nominal)
 locked to sampling frequency
 Level -20dB(FS) & -18dB(FS)
 Refer to format selection guide
 Channels 4 x stereo pairs (8 x channels)

Battery Life

3 hours continuous

Power Requirements

3 Volt Lithium Ion battery Type DL/CR123
 Optional 3v AC power adaptor 110/240 (+/- 10%) 50/60Hz

Mechanical

Length 172mm
 Diameter 22mm
 Weight 175g (without battery)

Environmental

Temperature 0 to 40 degrees C.
 EMI/RFI Complies with FCC, EU EMC Directive

Electronic Visuals Ltd reserve the right to change or modify

*penpal*HSD is a registered trademark of Electronic Visuals Ltd

Format Selection Guide

LED Red ●
 LED Green ●
 LED Orange ●
 LED Red flickering ⚙
 LED Green flickering ⚙

	LED1	LED2	LED3	Audio level
1080i / 59.94	●	●	⚙	- 20dB
1080p / 29.97	●	●	⚙	- 20dB
1080p / 23.98	●	●	⚙	- 20dB
1080sF / 29.97	●	●	⚙	- 20dB
1080sF / 23.98	●	●	⚙	- 20dB
1035i / 59.94	●	●	⚙	- 20dB
720p / 59.94	●	●	⚙	- 20dB
(PAL)				
576i / 50	⚙	●	●	- 18dB
(NTSC)				
480i / 59.94	⚙	●	⚙	- 20dB
			LED4	
Audio	off			●
Audio	on			●



20 Ferry Lane
 Wraysbury, Staines,
 Middlesex TW19 6HG
 UK
 Tel: +44(0)1784 483311
 Fax: +44(0)1784 483918
 E: info@electronic-visuals.com
 W: www.electronic-visuals.com

*penpal*HSD/59.

User Manual

Prepare to be amazed!

penpal-HSD/59.

Operating Instructions

Penpal-HSD is high quality, high and standard definition, broadcast standard, test pattern generator operating in serial digital environments (SMPTE 292M & 259M). Because all processing lies in the digital domain, no degradation occurs, regardless of pattern repetition.

POWER REQUIREMENTS

Penpal-HSD can be powered using the optional 3 volt AC power adaptor. Its true portability lies in powering the unit from a 3v lithium battery—DL/CR123. Operating in this mode Penpal-HSD will run continuously for over 3 hours.

* to save battery life, Penpal-HD will automatically shut down after 17 minutes of non use.

CONNECTION

Penpal-HSD can easily be connected to any type of video equipment or patch bay via the female BNC connector using the applicable BNC cable.

OPERATION

The video patterns have been grouped making it easier and quicker to access the desired pattern. The two buttons on the barrel will operate and control every function of Penpal-HSD. The top button **1** operates the power on/off and access to all video patterns. Depress button **1** for 1 second, Penpal-HSD will power up and display a pattern. The LED's will also light to confirm that power is on. (When Penpal-HSD is powered up it will display the last pattern previously used). Each click of button **1** will display the next pattern in the group. To go to the next group of patterns, double click button **1** again. Each subsequent click will display the next pattern in that group. To change the video format, double click button **2**. LED 1, 2 & 3 indicates the selected format.

To select audio test signal mode, single click button **2**. When no audio is selected, LED 4 lights to Red. When audio signal is present LED 4 lights to green.

With audio tone on, single clicks of button **2** will select required audio signal.

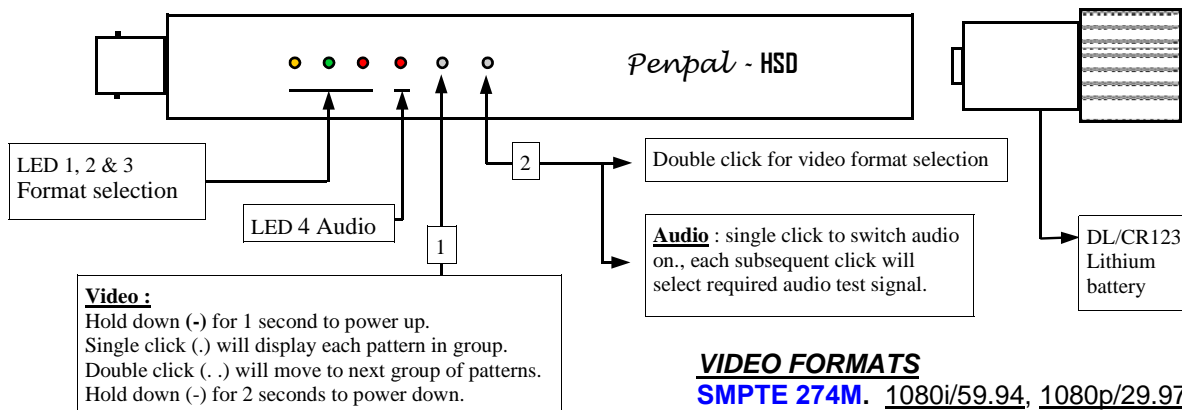

LED SUMMARY

LED 1 (video lines)

- Red. 720
- Green. 1080
- Orange. 1035
- Green flashing. PAL
- Red flashing. NTSC

LED 2 (scanning)

- Red. Progressive
- Green. Interlace
- Orange. Segmented Frame

LED 3 (field or frame rate)

- Red flashing. 59.94 / 29.27Hz
- Green flashing. 23.98Hz
- Orange. 50 / 25Hz

LED 4 (audio)

- Red. audio off
- Green. audio on

Battery operated: LED's will pulse approx every 5 seconds and illuminate for 2 seconds whenever a button is pressed.

Mains adaptor: LED's on continuously.

VIDEO FORMATS

SMPTE 274M. 1080i/59.94, 1080p/29.97, 1080p/23.98, 1080sF/29.97, 1080sF/23.98.

SMPTE 296M. 720p/59.94,

SMPTE 260M. 1035i/59.94,

SMPTE 259M. 576i/50(PAL), 480i/59.94(NTSC).

VIDEO TEST PATTERNS

Group 1: 100% colour bars, 75% colour bars, SMPTE HD (SD compatible) bars, 100% bars & red.

Group 2 : SDI checkfield matrix, ARC/APM 16:9 & 4:3. Y pulse & bar (HD), UV pulse & bar (HD), 2T Modulated Pulse & Bar (SD), Full-field line 17 ITS (SD).

Group 3 : 5 step Y staircase, 5 step UV staircase (HD), Limit YUV ramp, Shallow Y ramp, 5 step mod stair (SD)

Group 4 : 60% Y sweep (30MHz) with markers (HD), 60% Y sweep (5.5MHz) with markers (SD), 60% UV sweep (15MHz) with markers (HD), 60% UV sweep (2.75MHz) with markers (SD), Y multiburst, UV multiburst.

Group 5 : SD PLUGE, convergence, tartan bars, 1 field in 8 white bar.

Group 6: white, black, red, yellow.

Group 7 : green, blue, magenta, cyan.

Group 8 : Y zone plate, **moving Y zone plate**, moving Y vertical bar, moving Y diagonal bar.

AUDIO TEST SIGNALS

Audio Off

Audio signal 1 : 1kHz tone on pair 1 only.

Audio signal 2 : Steady 1kHz tone on pair 1, Steady 444Hz tone on pair 2, Broken 1kHz on pair 3, Broken 444Hz on pair 4.

Audio signal 3 : 1kHz tone on 4 stereo pairs - left channels steady, right channels Broken.